



Electric wire rope hoists

ABUS GM wire rope hoists: Quality at your fingertips



Absolute reliability is one of the most important features for a wire rope hoist. To ensure the highest possible reliability levels in day-to-day operation, our crane systems are made to the most stringent quality standards. ABUS GM electric wire rope hoists are produced using the most advanced technology available and continue to bear witness to their reliability, safety and durability year after year, from motor to rope, gearbox, brakes and electrical and electronic systems.

Apart from quality, versatility is an outstanding feature of ABUS GM electric wire rope hoists. These units cover an extremely wide load capacity range, from 1,000 kg to 100 tonnes. And the comprehensive standard equipment means that even a standard ABUS electric wire rope hoist is a versatile unit right from the start. Additional equipment is also available for special applications. Order an ABUS GM electric wire rope hoist and you can be sure that you have opted for a top-quality material handling unit.



Type D crab units on double-girder overhead travelling cranes



Type E monorail hoist on a type VS pillar jib crane



Two type E monorail hoists on type ELV single-girder overhead travelling cranes



Type E monorail hoist on a type EDL underslung overhead travelling crane

ABUS GM wire rope hoists – quality features



Hoisting gear
Lightweight gear units with silent-running flat bevelled gears deliver the torque required. Four different gear ratios are available for each model.



Hoist motor
Sturdy pole change motors with cylindrical rotors and integrated safety brakes are the power house of ABUS wire rope hoists.



Rope guide
A resilient low-friction plastic rope guide designed as an expanding ring provides positive guidance for the rope. The rope guide also reduces wear on the rope and rope drum. It is also easy to install, reducing maintenance requirements for the unit as a whole.



Bottom block
The elegant bottom blocks are equipped with protective edging around the rope opening. Long service lives and high safety levels are outstanding features of the resilient annealed steel rollers with machined rope grooves and annealed load hooks.



Safety brake
The dual-disk electromagnetic brake features automatic braking in the event of a power failure. Asbestos-free brake linings designed for approx. 1 million braking operations make for long maintenance intervals.



Cross travel drive
Two compact epicyclic reduction gears with pole-changing brake motors directly drive two wheels.



Cross travel trolley
Hoist trolleys are fitted with four flanged wheels with permanently lubricated roller bearings, designed for use on tracks with parallel flanges. Wheels for tracks with inclined flanges are available as an option.



ABUS emergency limit switch
Two standard switching points for the highest hook position ensure double safety.

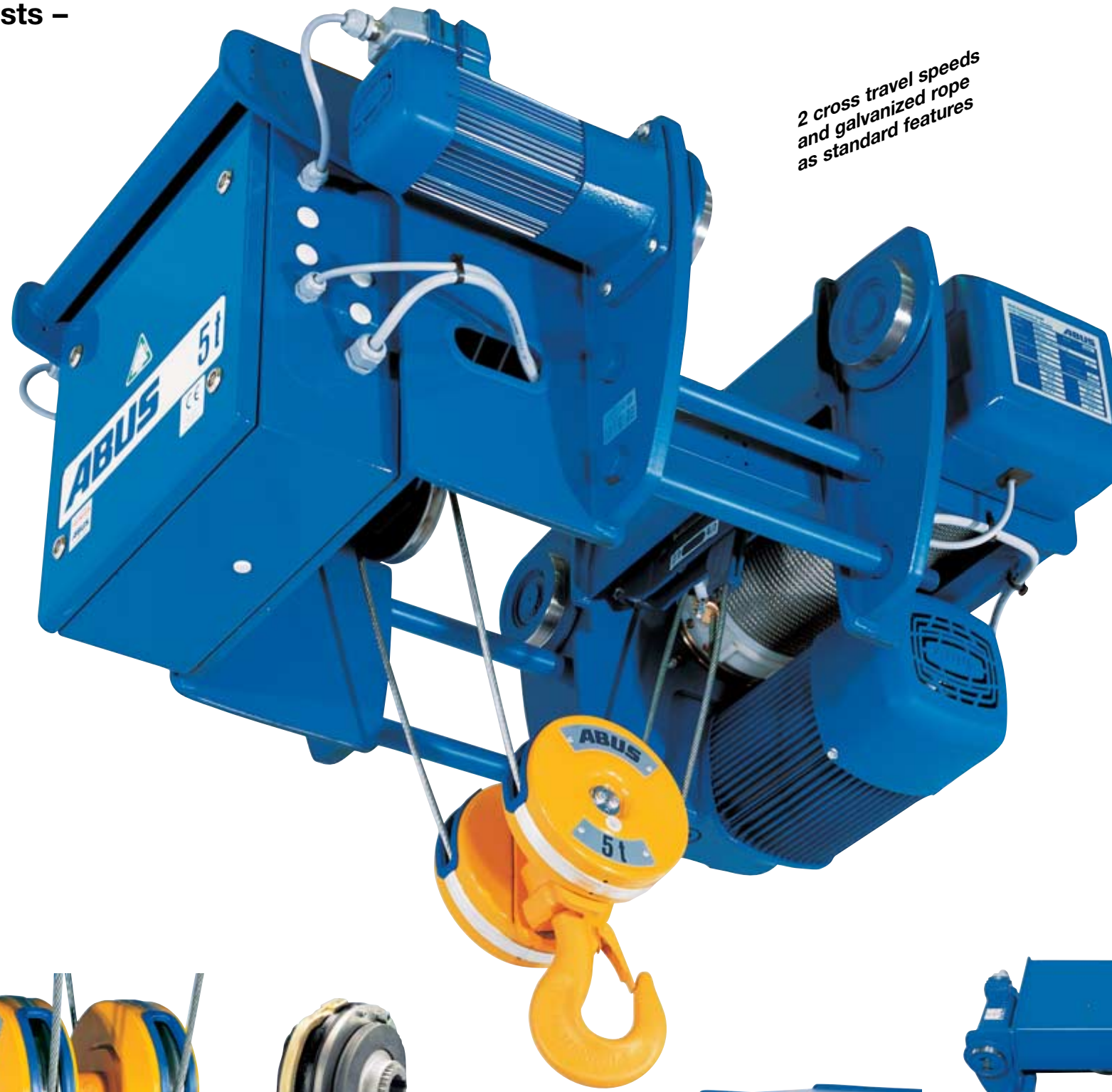

2 cross travel speeds and galvanized rope as standard features

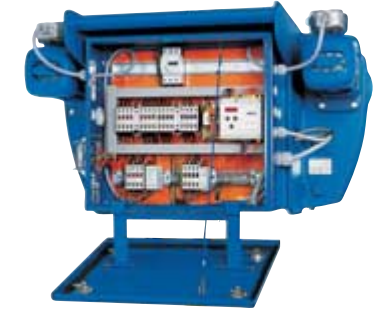

Electrical system
The easy-to-service control system with ABUS LIS control unit includes motor protection functions, operating hours meter and overload protection function.



Easy plug-in connector
The factory fitted ABUS plug and socket connections reduce installation and maintenance work to a minimum. Connections are easy to assemble and dismantle. Furthermore incorrect connections are impossible.

ABUS GM wire rope hoists for single-girder cranes

Type E – monorail hoist

A compact designed monorail hoist with low headroom dimensions and two direct drive cross travel motors. The cross travel trolley is adjustable to suit various flange widths. These most cost effective and frequently ordered hoists have a load range from 1 t to 12.5 t SWL.

Model	Reeving	Load cap. (t)	Hook path (m)			C (mm)	H (mm)
GM 800	4/1	3,2	6	9	-	400	176
GM 1000	2/1	2,5	12	18	24	567	196
	4/1	5,0	6	9	-	500	196
GM 2000	2/1	3,2	12	18	24	580	213
	4/1	6,3	6	9	-	500	213
GM 3000	2/1	6,3	12	20	30	665	251
	4/1	12,5	6	10	-	580	251
GM 5000	2/1	10,0	12	20	30	830	273
GM 6000	2/1	10,0	12	20	-	830	293
	2/1	12,5	12	-	-	830	293

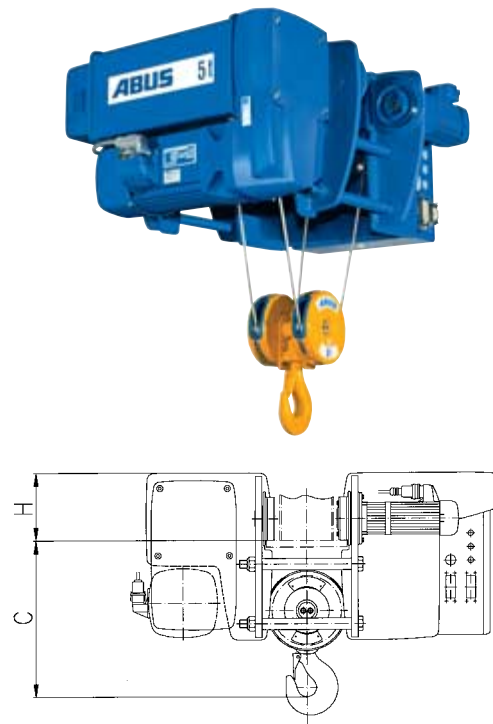

Type S – side-mounted hoist

With its optimized hook height, this hoist, which can be used on crane bridges with a span of up to 35 m or more, has advantages over other types in terms of investment return.

- Compared with a single-girder crane using a type E monorail hoist, the building height can be reduced.
- Compared with a double-girder crane of about the same height, the loads on the crane track and the building are significantly lower.



Model	Reeving	Load cap. (t)	Hook path (m)			C (mm)	H (mm)
GM 800	4/1	3,2	6	9	343	238	
GM 1000	4/1	5,0	6	9	420	278	
GM 2000	4/1	6,3	6	9	440	280	
GM 3000	2/1	5,0	12	20	30	700	280
	4/1	10,0	6	10	15	555	340

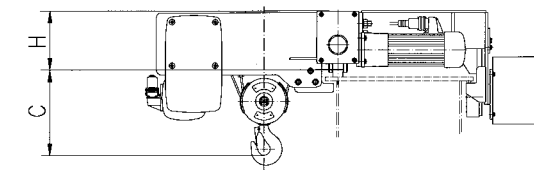

Support rollers with swivel mount

Type U – monorail hoist with twin trolleys

A monorail hoist with twin trolleys for high load capacities and long hook paths. Cross travel trolley designed for direct drive without exposed reduction gearing. As the load is distributed over eight wheels, ordinary rolled section beams can be used for monorail track applications. With short spans, even high-load cranes can be operated on ordinary rolled section beams using this hoist. Load capacity range: 6.3 t to 25 t.

Model	Reeving	Load cap. (t)	Hook path (m)				C (mm)	H (mm)
GM 5000	4/1	20	6	10	15	18,5	1132	180
GM 6000	2/1	12,5	12	20	30	37	1256	180
	4/1	25	6	10	15	18,5	1241	180

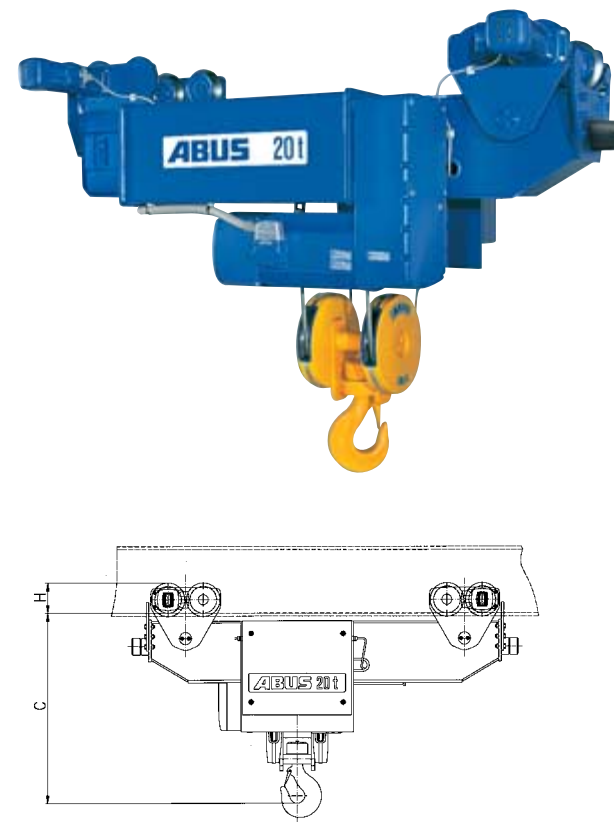

Comparison of the headroom of different hoists, SWL 10 t, span 25 000 mm

Single-girder crane with type E monorail hoist

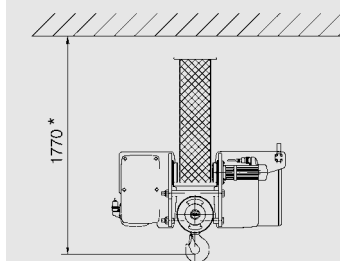

ELK

Double-girder crane with type D crab unit

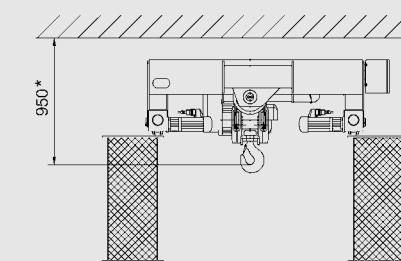

ZLK

Single-girder torsion box crane with type S side-mounted hoist

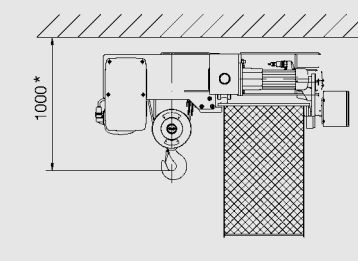

ELS

* Observe national regulations regarding clearance dimensions!

ABUS GM crab units for double-girder cranes

Type D – standard crab unit

A compact designed crab unit for the medium load capacity range, with articulated end carriage joints ensuring positive contact of all four wheels with the track, with two direct drive cross travel motors. Load capacity range: 1 t to 63 t.

Model	Reeving	Load cap. (t)	Hook path (m)			C (mm)	H (mm)
GM 800	4/1	3,2	6	9	-	149	460
GM 1000	4/1	5,0	6	9	12	200	500
GM 2000	2/1	3,2	12	18	24	300	500
	4/1	6,3	6	9	12	220	500
GM 3000	2/1	6,3	12	20	30	320	560
	4/1	12,5	6	10	15	260	590
	6/1	20,0	6,7	10	-	429	756
GM 5000	2/1	10,0	12	20	30	445	610
	4/1	20,0	6	10	15	385	720
	6/1	32,0	6,6	10	12,3	611	945
GM 6000	2/1	12,5	12	20	30	520	660
	4/1	25,0	6	10	15	275	900
	6/1	40,0	4	6,6	10	611	945
GM 7000	2/1	20,0	16	30	45	572	987
	4/1	40,0	8	15	22,5	500	995
	4/2 ¹⁾	20,0	7,3	17	27,3	236	987
	6/1	63,0	5,3	10	15	722	1218
	8/2 ¹⁾	40,0	4,2	9	14,2	521	1015

¹⁾ True vertical lift (without hook movement or turn)
Low headroom version DA on application

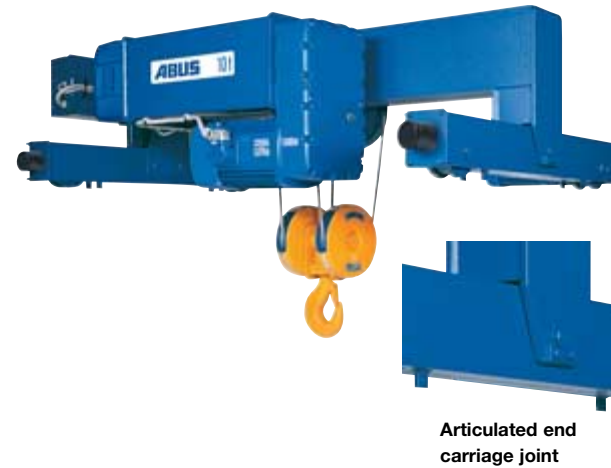

Articulated end carriage joint

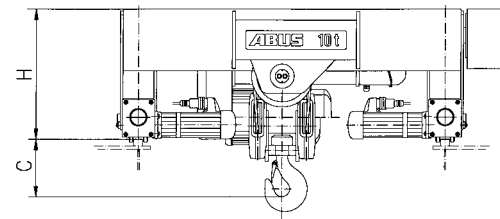

Type DA – low headroom crab unit

In contrast to type D, the supporting member with the hoist between the end carriages is equipped with articulated joints. The hoist headroom is therefore reduced to a minimum. This is the option to use where very little space is available above the crane, as an alternative to type DQA, also a low headroom option.



Type DQA – ultra low headroom crab unit

An ultra low headroom crab unit with the rope drum axis in the direction of cross travel, articulated end carriage joints ensuring positive contact of all four wheels with the track, two direct drive cross travel motors. Load capacity range: 1 t to 40 t.

Model	Reeving	Load cap. (t)	Hook path (m)			C (mm)	H (mm)
GM 2000	2/1	3,2	12	18	-	525	270
	4/1	6,3	6	9	-	445	270
GM 3000	2/1	6,3	12	20	-	640	270
	4/1	12,5	6	10	-	555	270
GM 5000	2/1	10,0	12	20	-	810	270
	4/1	20,0	6	10	15	715	305
GM 6000	2/1	12,5	12	20	-	870	270
	4/1	25,0	6	10	15	755	375
GM 7000	4/1	40,0	8	15	-	998	500

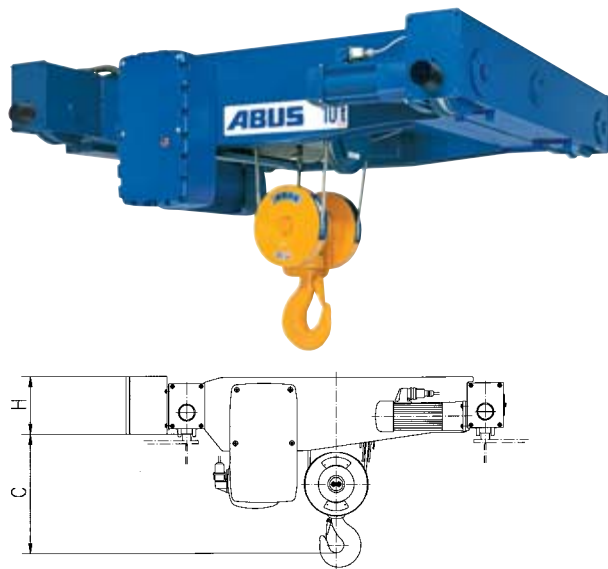

Type Z – twin barrel crab unit

A compact designed crab unit with twin barrels and articulated end carriage joints ensuring positive contact of all four wheels with the track, two direct drive cross travel motors. Load capacity range: 8 t to 100 t.

Model	Reeving	Load cap. (t)	Hook path (m)			C (mm)	H (mm)
GM 5000	4/2	20,0	12	20	30	413	985
	8/2	40,0	6	10	15	635	1030
GM 6000	4/2	25,0	12	20	30	419	1008
	8/2	50,0	6	10	15	643	1080
GM 7000	4/2	40,0	16	30	45	473	1107
	6/2	63,0	10,6	20	30	722	1218
	8/2	80,0	8	15	22,5	740	1275
	10/2	100,0	12	18	22	810	1265

Low headroom version ZA available on application

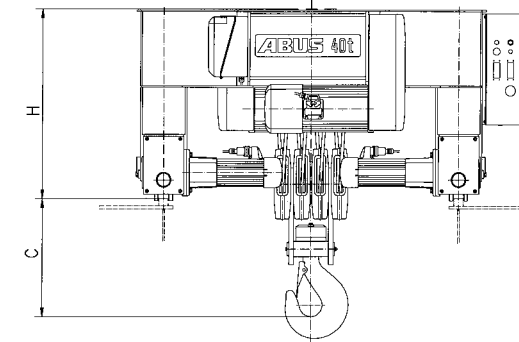
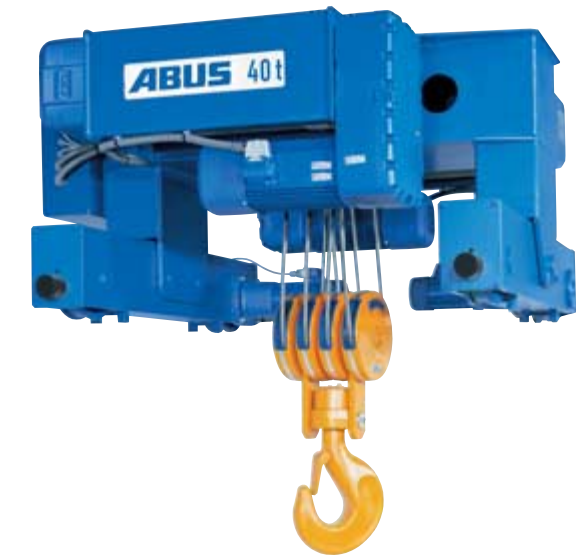

Type ZA – low headroom twin barrel crab unit

In contrast to type Z, the supporting member with the hoist between the end carriages is equipped with articulated joints. The hoist headroom is therefore reduced to a minimum. This is the option to use where very little headroom is available above the crane.



Vario-Speed for type Z

Vario-Speed offers four different lifting speeds for twin barrel hoists. This feature is obtained by operating the two pole change hoist motors either together or alternately. The operating times of the hoist motors in alternating operation are controlled by special software as a function of travel, taking into consideration the maximum rope deflection allowed. Four lifting speeds are obtained by combining parallel and alternating operation.

- 1/12 ½ precision lifting speed
- 1/6 precision lifting speed
- 1/2 ½ main lifting speed
- 1/1 main lifting speed



Cross travel drives for type Z



Wheel diameter ≤ 280 mm
Epicyclic geared motors



Wheel diameter ≥ 400 mm
Flat-geared motors

ABUS GM wire rope hoists: special designs

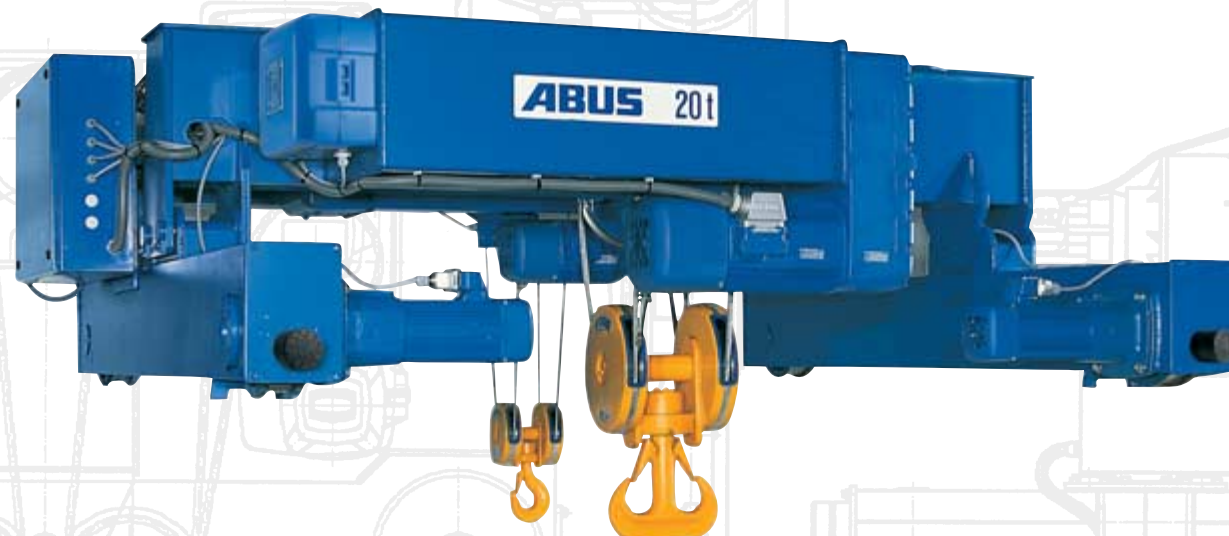

A number of special designs are available for various applications. Our specialist staff will be pleased to advise you.

Accessories

ABUS LIS control system – the nerve centre of your ABUS wire rope hoist

ABUS wire rope hoists are equipped with an intelligent LIS control system, available in two versions – LIS-SE and LIS-SV. Both versions feature an overload protection device which reliably protects the hoist against overloading. While the LIS-SV uses a strain gauge signal to measure the load, the LIS-SE calculates the current load on the hook on the basis of three-phase current and voltage measurements made while the motor is running.

Both types of control unit may be equipped with an optional load display for visualizing the load.

All LIS control units are equipped with an operation hours meter for determining the expended portion of the service life. For precise determination of the remaining service life, a load population recorder in accordance with FEM 9.755 is available as an option. This ensures safe working periods over the entire service life of the hoist. The load population recorder is designed to allow the relevant values to be read out easily by the operator.

In addition to these features, LIS control units are designed for a number of other functions to ensure safe, low-maintenance operation of all ABUS wire rope hoists. The combination of actively fail-safe electric and electronic circuitry meets the highest safety requirements and is in accordance with the diversity and active fail-safe requirements of the applicable standards.

The integrated motor overcurrent protection system and the guided start-up function reliably protect the hoist motor against thermal overloading. If the motor current continuously exceeds the maximum value, the overcurrent protection function shuts down the motor. The guided start-up function prevents excessive inching operation when the high hoist speed is selected.

Another function with considerable benefit to the user is regenerative braking. During each braking operation from high hoist speed, the motor is briefly operated as a generator to slow the hoist before the mechanical brakes are operated, significantly extending the service life of the brake linings.

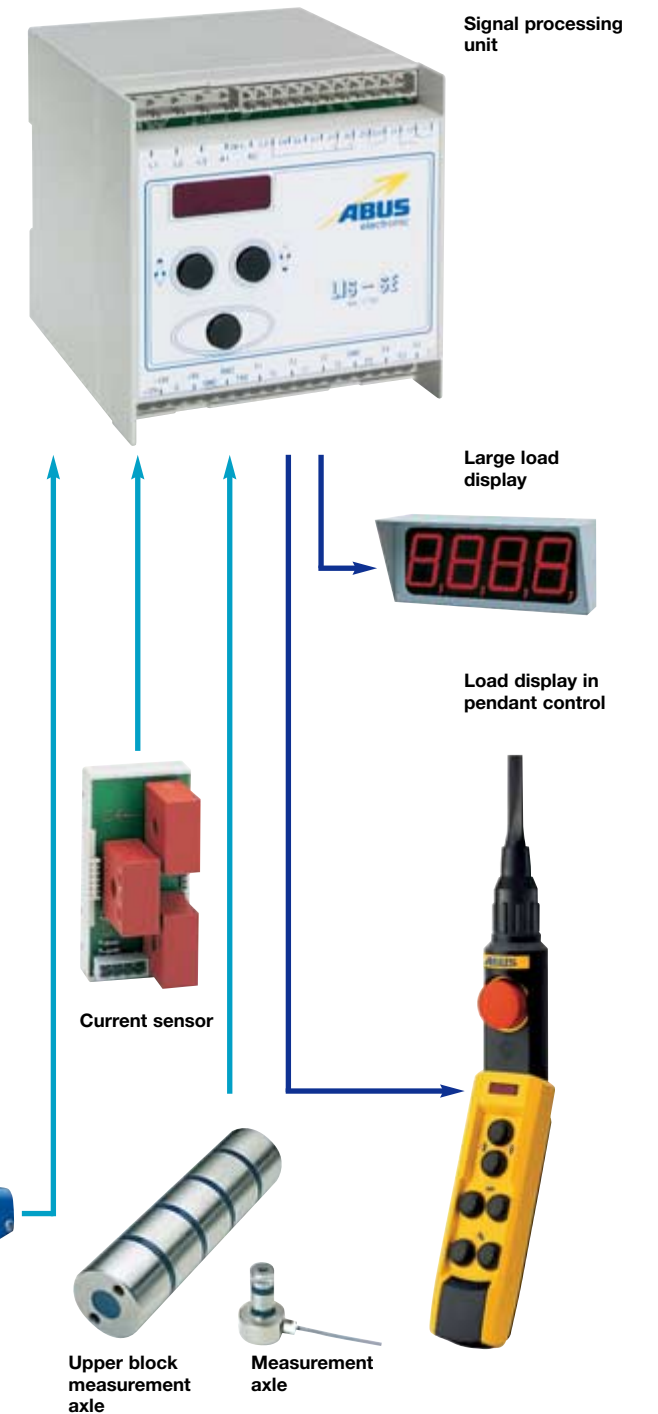

Technical features	LIS SV	LIS SE
Overload protection	●	●
Load evaluation by strain gauge sensors	●	
Load evaluation by current/voltage measurements		●
Adjustment by integrated digital terminal with 4-digit, 7-segment display	●	●
Malfunction signalling by integrated 4-digit display or load display	●	●
Second shut-down point and external part-load switch ready for activation (option)	●	●
Hoist operating data stored in memory protected against power failure	●	●

Technical features	LIS SV	LIS SE
Load totalization and monitoring for a maximum of three hoists	●	
Load display in pendant control or large load display (option)	●	●
Load population recorder to FEM 9.755 (option)	●	●
Hoist control functions	●	●
Isolated control signal circuits	●	●
Modular compact design	●	●
All connections by plug-in connectors	●	●

Accessories



ABUliner frequency converter

The ABUliner, a microprocessor-controlled frequency converter unit, allows infinitely variable speed control.

When fitted to a cross travel drive, the ramps set ensure smooth acceleration and deceleration. The ramp is adapted to the load to prevent large loads from swinging.

If an ABUliner is fitted to a hoist motor, the motor can be operated at up to twice the rated maximum lifting speed, depending on the actual load (this function is optional). This feature permits significant time savings, especially on systems with large hook paths. The acceleration ramp and the braking ramp can be set separately.

For applications requiring extremely low lifting speeds, such as toolmaking and mould production, the ABUliner can be installed in such a way as to operate only on the precision lifting speed. With this version, infinitely variable speed control is only possible if the precision lifting speed is selected.



Electronic synchronization control system

The electronic synchronization control system compensates for differences in the speeds of several hoists operated together as a result of different loads.

The patented unit controls two or more hoists in synchronized operation with a minimum of effort, without switching off the faster-running motor in main lifting speed.

The electronic synchronization control system can be fitted inexpensively to standard hoists driven by pole change motors. No mechanical modifications or additional

electronic components are needed. Differences in the levels of the lifting height are easily compensated by individual operation of the hoists before the system is switched to synchronized-speed operation. Time-consuming adjustment of the length of the individual load lifting tackles is therefore no longer necessary.

With a separate control unit, the synchronization control system can also be fitted to hoist motors controlled by ABUliners.



Electronic motor control systems

The ABUS AZS electronic smooth starting unit, which is designed for use both with long and cross travel motors, allows smooth acceleration to the design speed.

The patented ABUS SU smooth switching relay is triggered each time the unit is switched from high to low speed, ensuring a significant reduction in the braking torque caused by operation of the motor as a generator and minimizing load swing.

The smooth starting unit and the smooth switching relay work harmoniously in combination, making for extremely convenient operation.



Electric emergency lowering system for hoist motors

The emergency lowering system ensures that the load can be lowered safely even in the event of a power supply failure. If the mains power supply is interrupted, the operator can initiate controlled lowering by pressing the "lowering" button on the pendant control. The lowering operation can be stopped at any point.

During emergency lowering, power for the motor brake is supplied by a battery. To prevent uncontrolled lowering, one winding of the pole change motor is operated as a generator.

ABUS wire rope hoist selection table

ABUS wire rope hoist selection table for monorail hoists, type E / type S										
SWL kg	Reeving 4/1					Reeving 2/1				
	Type	FEM	ISO	Hook path m	V _{hoist} m/min	Type	FEM	ISO	Hook path m	V _{hoist} m/min
1 000	GM 810	4m	M7	6; 9	8/1.3; 6.3/1; 5/0.8; 4/0.66	GM 1010*	4m	M7	12; 18; 24	16/2.6; 12.5/2; 10/1.6; 8/1.3
1 250	GM 812	4m	M7	6; 9	8/1.3; 6.3/1; 5/0.8; 4/0.66	GM 1012*	4m	M7	12; 18; 24	16/2.6; 12.5/2; 10/1.6; 8/1.3
1 600	GM 816	4m	M7	6; 9	8/1.3; 6.3/1; 5/0.8; 4/0.66	GM 1016* GM 2016*	3m 3m	M6 M6	12; 18; 24 12; 18; 24	16/2.6; 12.5/2; 10/1.6; 8/1.3 16/2.6; 12.5/2; 10/1.6; 8/1.3
2 000	GM 820 GM 820 GM 1020	3m 4m 4m	M6 M7 M7	6; 9 6; 9 6; 9	8/1.3; 6.3/1; 5/0.8; 4/0.66 8/1.3; 6.3/1; 5/0.8; 4/0.66 8/1.3; 6.3/1; 5/0.8; 4/0.66	GM 1020* GM 2020*	3m 3m	M6 M6	12; 18; 24 12; 18; 24	16/2.6; 12.5/2; 10/1.6; 8/1.3 16/2.6; 12.5/2; 10/1.6; 8/1.3
2 500	GM 825 GM 825 GM 1025	2m 3m 4m	M5 M6 M7	6; 9 6; 9 6; 9	6.3/1 8/1.3; 6.3/1; 5/0.8; 4/0.66 8/1.3; 6.3/1; 5/0.8; 4/0.66	GM 1025* GM 2025* GM 3025	2m 2m 4m	M5 M5 M7	12; 18; 24 12; 18; 24 12; 20; 30*	12.5/2; 10/1.6; 8/1.3 16/2.6; 12.5/2; 10/1.6; 8/1.3 16/2.6; 12.5/2; 10/1.6; 8/1.3
3 200	GM 832 GM 1032 GM 2032	2m 3m 3m	M5 M6 M6	6; 9 6; 9 6; 9	6.3/1; 5/0.8; 4/0.66 8/1.3; 6.3/1; 5/0.8; 4/0.66 8/1.3; 6.3/1; 5/0.8; 4/0.66	GM 2032* GM 3032 GM 3032	1Am 3m 4m	M4 M6 M7	12; 18; 24 12; 20; 30* 12; 20; 30*	12.5/2; 10/1.6; 8/1.3 12.5/2; 10/1.6 16/2.6; 12.5/2; 10/1.6; 8/1.3
4 000	GM 1040 GM 2040 GM 3040	3m 3m 4m	M6 M6 M7	6; 9 6; 9 6; 10; 15	8/1.3; 6.3/1; 5/0.8; 4/0.66 8/1.3; 6.3/1; 5/0.8; 4/0.66 8/1.3; 6.3/1; 5/0.8; 4/0.66	GM 3040 GM 3040 GM 5040* GM 5040*	2m 3m 3m 4m	M5 M6 M6 M7	12; 20; 30* 12; 20; 30* 12; 20; 30 12; 20; 30	10/1.6 16/2.6; 12.5/2; 10/1.6; 8/1.3 16/2.6 16/2.6; 12.5/2; 10/1.6; 8/1.3
5 000	GM 1050 GM 2050 GM 3050	2m 2m 4m	M5 M5 M7	6; 9 6; 9 6; 10; 15	6.3/1; 5/0.8; 4/0.66 8/1.3; 6.3/1; 5/0.8; 4/0.66 8/1.3; 6.3/1; 5/0.8; 4/0.66	GM 3050 GM 5050* GM 6050* GM 6050*	2m 3m 3m 4m	M5 M6 M6 M7	12; 20; 30* 12; 20; 30 12; 20 12; 20	12.5/2; 10/1.6; 8/1.3 16/2.6; 12.5/2; 10/1.6; 8/1.3 16/2.6 12.5/2; 10/1.6; 8/1.3
6 300	GM 2063 GM 3063 GM 3063	1Am 3m 4m	M4 M6 M7	6; 9 6; 10; 15 6; 10; 15	6.3/1; 5/0.8; 4/0.66 6.3/1; 5/0.8 8/1.3; 6.3/1; 5/0.8; 4/0.66	GM 3063* GM 5063* GM 5063* GM 6063* GM 6063*	1Am 2m 3m 2m 3m	M4 M5 M6 M5 M6	12; 20; 30 12; 20; 30 12; 20; 30 12; 20 12; 20	10/1.6; 8/1.3 16/2.6 12.5/2; 10/1.6; 8/1.3 16/2.6 12.5/2; 10/1.6; 8/1.3
8 000	GM 3080 GM 3080	2m 3m	M5 M6	6; 10; 15 6; 10; 15	5/0.8 8/1.3; 6.3/1; 5/0.8; 4/0.66	GM 5080* GM 6080* GM 6080*	2m 2m 3m	M5 M5 M6	12; 20; 30 12; 20 12; 20	12.5/2; 10/1.6; 8/1.3 12.5/2 10/1.6; 8/1.3
10 000	GM 3100	2m	M5	6; 10; 15	6.3/1; 5/0.8; 4/0.66	GM 5100* GM 6100*	1Am 2m	M4 M5	12; 20; 30 12; 20	10/1.6; 8/1.3 10/1.6; 8/1.3
12 500	GM 3125*	1Am	M4	6; 10	5/0.8; 4/0.66	GM 6125*	1Am	M4	12	8/1.3

* not available with type S

ABUS wire rope hoist selection table for monorail hoists with twin trolleys, type U										
SWL kg	Reeving 4/1					Reeving 2/1				
	Type	FEM	ISO	Hook path m	V _{hoist} m/min	Type	FEM	ISO	Hook path m	V _{hoist} m/min
5 000						GM 6050 GM 6050	3m 4m	M6 M7	12; 20; 30; 37 12; 20; 30; 37	16/2.6 12.5/2; 10/1.6; 8/1.3
6 300						GM 6063 GM 6063	2m 3m	M5 M6	12; 20; 30; 37 12; 20; 30; 37	16/2.6 12.5/2; 10/1.6; 8/1.3
8 000	GM 5080 GM 5080	3m 4m	M6 M7	6; 10; 15; 18.5 6; 10; 15; 18.5	8/1.3 8/1.3; 6.3/1; 5/0.8; 4/0.66	GM 6080 GM 6080	2m 3m	M5 M6	12; 20; 30; 37 12; 20; 30; 37	12.5/2 10/1.6; 8/1.3
10 000	GM 5100 GM 6100 GM 6100	3m 3m 4m	M6 M6 M7	6; 10; 15; 18.5 6; 10; 15; 18.5 6; 10; 15; 18.5	8/1.3 8/1.3 6.3/1; 5/0.8; 4/0.66	GM 6100	2m	M5	12; 20; 30; 37	10/1.6; 8/1.3
12 500	GM 5125 GM 5125 GM 6125 GM 6125	2m 3m 2m 3m	M5 M6 M5 M6	6; 10; 15; 18.5 6; 10; 15; 18.5 6; 10; 15; 18.5 6; 10; 15; 18.5	8/1.3 6.3/1; 5/0.8; 4/0.66 8/1.3 6.3/1; 5/0.8; 4/0.66	GM 6125	1Am	M4	12; 20; 30; 37	8/1.3
16 000	GM 5160 GM 6160 GM 6160	2m 2m 3m	M5 M5 M6	6; 10; 15; 18.5 6; 10; 15; 18.5 6; 10; 15; 18.5	6.3/1; 5/0.8; 4/0.66 6.3/1 5/0.8; 4/0.66					
20 000	GM 5200 GM 6200	1Am 2m	M4 M5	6; 10; 15; 18.5 6; 10; 15; 18.5	5/0.8; 4/0.66 5/0.8; 4/0.66					
25 000	GM 6250	1Am	M4	6; 10; 15; 18.5	4/0.66					

All data may be subject to changes in technical specifications

ABUS wire rope hoist selection table

ABUS wire rope hoist selection table for crab units, type D / type DB										
SWL kg	Reeving 4/1 (6/1)					Reeving 2/1				
	Type	FEM	ISO	Hook path m	V _{hoist} m/min	Type	FEM	ISO	Hook path m	V _{hoist} m/min
1000	GM 810	4m	M7	6; 9	8/1.3; 6.3/1; 5/0.8; 4/0.66	GM 2010	4m	M7	12; 18; 24	16/2.6; 12.5/2; 10/1.6; 8/1.3
1250	GM 812	4m	M7	6; 9	8/1.3; 6.3/1; 5/0.8; 4/0.66	GM 2012	4m	M7	12; 18; 24	16/2.6; 12.5/2; 10/1.6; 8/1.3
1600	GM 816	4m	M7	6; 9	8/1.3; 6.3/1; 5/0.8; 4/0.66	GM 2016	3m	M6	12; 18; 24	16/2.6; 12.5/2; 10/1.6; 8/1.3
2000	GM 820	3m	M6	6; 9	8/1.3; 6.3/1	GM 2020	3m	M6	12; 18; 24	16/2.6; 12.5/2; 10/1.6; 8/1.3
	GM 820	4m	M7	6; 9	8/1.3; 6.3/1; 5/0.8; 4/0.66					
	GM 1020	4m	M7	6; 9	8/1.3; 6.3/1; 5/0.8; 4/0.66					
2500	GM 825	2m	M5	6; 9	6.3/1	GM 2025	2m	M5	12; 18; 24	16/2.6; 12.5/2; 10/1.6; 8/1.3
	GM 825	3m	M6	6; 9	8/1.3; 6.3/1; 5/0.8; 4/0.66					
	GM 1025	4m	M7	6; 9; 12	8/1.3; 6.3/1; 5/0.8; 4/0.66					
3200	GM 832	2m	M5	6; 9	6.3/1; 5/0.8; 4/0.66	GM 2032	1Am	M4	12; 18; 24	12.5/2; 10/1.6; 8/1.3
	GM 1032	3m	M6	6; 9; 12	8/1.3; 6.3/1; 5/0.8; 4/0.66					
	GM 2032	3m	M6	6; 9; 12	8/1.3; 6.3/1; 5/0.8; 4/0.66					
4000	GM 1040	3m	M6	6; 9; 12	8/1.3; 6.3/1; 5/0.8; 4/0.66	GM 3040	2m	M5	12; 20; 30	10/1.6
	GM 2040	3m	M6	6; 9; 12	8/1.3; 6.3/1; 5/0.8; 4/0.66					
	GM 3040	4m	M7	6; 10; 15	8/1.3; 6.3/1; 5/0.8; 4/0.66					
5000	GM 1050 GM 2050 GM 3050	2m	M5	6; 9; 12	6.3/1; 5/0.8; 4/0.66	GM 3050	2m	M5	12; 20; 30	12.5/2; 10/1.6; 8/1.3
		2m	M5	6; 9; 12	8/1.3; 6.3/1; 5/0.8; 4/0.66					
		4m	M7	6; 10; 15	8/1.3; 6.3/1; 5/0.8; 4/0.66					
		3m	M6	12; 20	16/2.6					
		3m	M6	30; 37	16/2.6; 12.5/2; 10/1.6; 8/1.3					
6300	GM 2063 GM 3063 GM 3063	1Am	M4	6; 9; 12	6.3/1; 5/0.8; 4/0.66	GM 3063	1Am	M4	12; 20; 30	10/1.6; 8/1.3
		3m	M6	6; 10; 15	6.3/1; 5/0.8					
		4m	M7	6; 10; 15	8/1.3; 6.3/1; 5/0.8; 4/0.66					
		3m	M6	12; 20; 30; 37	12.5/2					
		3m	M6	12; 20; 30; 37	12.5/2; 10/1.6; 8/1.3					
8000	GM 3080 GM 3080 GM 5080 GM 5080	2m	M5	6; 10; 15	5/0.8	GM 5080	2m	M5	12; 20; 30; 37	12.5/2; 10/1.6; 8/1.3
		3m	M6	6; 10; 15	8/1.3					
		3m	M6	6; 10; 15; 18.5	8/1.3					
		4m	M7	6; 10; 15; 18.5	8/1.3; 6.3/1; 5/0.8; 4/0.66					
		4m	M7	6; 10; 15; 18.5	8/1.3; 6.3/1; 5/0.8; 4/0.66					
10000	GM 3100 GM 5100 GM 6100 GM 6100	2m	M5	6; 10; 15	6.3/1; 5/0.8; 4/0.66	GM 5100	1Am	M4	12; 20; 30; 37	10/1.6; 8/1.3
		3m	M6	6; 10; 15; 18.5	8/1.3; 6.3/1; 5/0.8; 4/0.66					
		3m	M6	6; 10; 15; 18.5	8/1.3					
		4m	M7	6; 10; 15; 18.5	6.3/1; 5/0.8; 4/0.66					
		3m	M6	6; 10; 15; 18.5	6.3/1; 5/0.8; 4/0.66					
12500	GM 3125 GM 5125 GM 5125 GM 6125 GM 6125	1Am	M4	6; 10; 15	5/0.8; 4/0.66	GM 6125	1Am	M4	12; 20; 30; 37	8/1.3
		2m	M5	6; 10; 15; 18.5	6.3/1; 8/1.3; 5/0.8; 4/0.66					
		3m	M6	6; 10; 15; 18.5	6.3/1; 5/0.8; 4/0.66					
		2m	M5	6; 10; 15; 18.5	8/1.3					
		3m	M6	6; 10; 15; 18.5	6.3/1; 5/0.8; 4/0.66					
16000	(GM 3160) GM 5160 GM 5160 GM 6160 GM 6160 GM 7160	1Am	M4	6.7; 10	4.2/0.7; 3.3/0.5; 2.7/0.4	GM 7160	2m	M5	16; 30; 45	12.5/2; 10/1.6; 8/1.3
		1Am	M4	6; 10; 15; 18.5	6.3/1; 5/0.8; 4/0.66					
		2m	M5	6; 10; 15; 18.5	6.3/1; 5/0.8; 4/0.66					
		2m	M5	6; 10; 15; 18.5	6.3/1					
		3m	M6	6; 10; 15; 18.5	5/0.8; 4/0.66					
20000	(GM 3200) GM 5200 GM 6200 GM 7200 GM 7200	1Bm	M3	6.7; 10	3.3/0.5; 2.7/0.4	GM 7200	1Am	M4	16; 30; 45	10/1.6; 8/1.3
		1Am	M4	6; 10; 15; 18.5	5/0.8; 4/0.66					
		2m	M5	6; 10; 15; 18.5	5/0.8; 4/0.66					
		2m	M5	8; 15; 22.5; 27.5	8/1.3					
		3m	M6	8; 15; 22.5; 27.5	8/1.3; 6.3/1; 5/0.8; 4/0.66					
25000	(GM 5250) GM 6250 GM 7250 GM 7250	1Am	M4	6.6; 10; 12.3	4.2/0.7; 3.3/0.5; 2.7/0.4					
		1Am	M4	6; 10; 15; 18.5	4/0.66					
		2m	M5	8; 15; 22.5; 27.5	8/1.3; 6.3/1					
32000	(GM 5320) (GM 6320) GM 7320	1Bm	M3	6.6; 10; 12.3	3.3/0.5; 2.7/0.4					
		1Am	M4	4; 6.6; 10; 12.3	3.3/0.5; 2.7/0.4					
		2m	M5	8; 15; 22.5; 27.5	6.3/1; 5/0.8; 4/0.66					
40000	(GM 6400) GM 7400	1Bm	M3	4; 6.6; 10; 12.3	2.7/0.4					
		1Am	M4	8; 15; 22.5; 27.5	5/0.8; 4/0.66					
50000	(GM 7500)	1Am	M4	5.3; 10; 15	4.1/0.6; 3.3/0.5; 2.6/0.4					
63000	(GM 7630)	1Bm	M3	5.3; 10; 15	3.3/0.5; 2.6/0.4					

All data may be subject to changes in technical specifications

Data for type DA and DQA available on application

ABUS wire rope hoist selection table

ABUS wire rope hoist selection table for crab units, type D / type DB										
SWL kg	Reeving 8/2 ¹⁾					Reeving 4/2 ¹⁾				
	Type	FEM	ISO	Hook path m	V _{hoist} m/min	Type	FEM	ISO	Hook path m	V _{hoist} m/min
8000						GM 7080	4m	M7	7.3; 17; 27.3	16/2.6; 12.5/2; 10/1.6; 8/1.3
10000						GM 7100	2m	M5	7.3; 17; 27.3	16/2.6
						GM 7100	3m	M6	7.3; 17; 27.3	16/2.6; 12.5/2; 10/1.6; 8/1.3
12500						GM 7125	2m	M5	7.3; 17; 27.3	16/2.6; 12.5/2
						GM 7125	3m	M6	7.3; 17; 27.3	12.5/2; 10/1.6; 8/1.3
16000	GM 7160	4m	M7	4.2; 9; 14.2	8/1.3; 6.3/1; 5/0.8; 4/0.66	GM 7160	2m	M5	7.3; 17; 27.3	12.5/2; 10/1.6; 8/1.3
	GM 7200	2m	M5	4.2; 9; 14.2	8/1.3	GM 7200	1Am	M4	7.3; 17; 27.3	10/1.6; 8/1.3
GM 7200	3m	M6	4.2; 9; 14.2	8/1.3; 6.3/1; 5/0.8; 4/0.66						
20000	GM 7250	2m	M5	4.2; 9; 14.2	8/1.3; 6.3/1					
	GM 7250	3m	M6	4.2; 9; 14.2	6.3/1; 5/0.8; 4/0.66					
25000	GM 7320	2m	M5	4.2; 9; 14.2	6.3/1; 5/0.8; 4/0.66					
	GM 7320	3m	M6	4.2; 9; 14.2	6.3/1; 5/0.8; 4/0.66					
32000	GM 7400	1Am	M4	4.2; 9; 14.2	5/0.8; 4/0.66					
	GM 7400	1Am	M4	4.2; 9; 14.2	5/0.8; 4/0.66					

¹⁾ Type in true vertical lift (without hook swinging or turning)

ABUS wire rope hoist selection table for twin barrel crab units, type Z / type ZB										
SWL kg	Reeving 8/2 (6/2); [10/2]					Reeving 4/2				
	Type	FEM	ISO	Hook path m	V _{hoist} m/min	Type	FEM	ISO	Hook path m	V _{hoist} m/min
8000						GM 5080	3m	M6	12; 20; 30; 37	16/2.6
10000						GM 5080	4m	M7	12; 20; 30; 37	16/2.6; 12.5/2; 10/1.6; 8/1.3
						GM 5100	3m	M6	12; 20; 30; 37	16/2.6
12500						GM 6100	3m	M6	12; 20; 30; 37	12.5/2; 10/1.6; 8/1.3
						GM 6100	4m	M7	12; 20; 30; 37	16/2.6
						GM 5125	2m	M5	12; 20; 30; 37	12.5/2; 10/1.6; 8/1.3
16000	GM 5160 GM 5160 GM 6160 GM 6160 GM 7160	3m	M6	6; 10; 15; 18.5	8/1.3	GM 5160	2m	M5	12; 20; 30; 37	12.5/2; 10/1.6; 8/1.3
		4m	M7	6; 10; 15; 18.5	8/1.3; 6.3/1; 5/0.8; 4/0.66					
		2m	M5	6; 10; 15; 18.5	10/1.6; 8/1.3					
		3m	M6	6; 10; 15; 18.5	16/2.6					
		4m	M7	6; 10; 15; 18.5	16/2.6; 12.5/2; 10/1.6; 8/1.3					
20000	GM 5200 GM 6200 GM 6200	3m	M6	6; 10; 15; 18.5	8/1.3; 6.3/1; 5/0.8; 4/0.66	GM 5200	1Am	M4	12; 20; 30; 37	10/1.6; 8/1.3
		3m	M6	6; 10; 15; 18.5	8/1.3					
		4m	M7	6; 10; 15; 18.5	6.3/1; 5/0.8; 4/0.66					
		2m	M5	6; 10; 15; 18.5	16/2.6					
		3m	M6	6; 10; 15; 18.5	16/2.6; 12.5/2; 10/1.6; 8/1.3					
25000	GM 5250 GM 5250 GM 6250 GM 6250 (GM 7250)	2m	M5	6; 10; 15; 18.5	8/1.3	GM 6250	1Am	M4	12; 20; 30; 37	8/1.3
		3m	M6	6; 10; 15; 18.5	6.3/1; 5/0.8; 4/0.66					
		2m	M5	6; 10; 15; 18.5	8/1.3					
		3m	M6	6; 10; 15; 18.5	6.3/1; 5/0.8; 4/0.66					
		4m	M7	10.6; 20; 30	10.4/1.6; 8.2/1.2; 6.6/1; 5.2/0.8					
32000	GM 5320 GM 6320 GM 6320 (GM 7320) (GM 7320) GM 7320	2m	M5	6; 10; 15; 18.5	6.3/1; 5/0.8; 4/0.66	GM 7320	2m	M5	16; 30; 45	12.5/2; 10/1.6; 8/1.3
		2m	M5	6; 10; 15; 18.5	6.3/1					
		3m	M6	6; 10; 15; 18.5	5/0.8; 4/0.66					
		2m	M5	10.6; 20; 30	10.4/1.6					
		3m	M6	10.6; 20; 30	10.4/1.6; 8.2/1.2; 6.6/1; 5.2/0.8					
40000	GM 5400 GM 6400 (GM 7400) (GM 7400) GM 7400 GM 7400	1Am	M4	6; 10; 15; 18.5	5/0.8; 4/0.66	GM 7400	1Am	M4	16; 30; 45	10/1.6; 8/1.3
		2m	M5	6; 10; 15; 18.5	5/0.8; 4/0.66					
		2m	M5	10.6; 20; 30	10.4/1.6; 8.2/1.2					
		3m	M6	10.6; 20; 30	8.2/1.2; 6.6/1; 5.2/0.8					
		2m	M5	8; 15; 22.5	8/1.3					
50000	GM 6500 (GM 7500) GM 7500 GM 7500	1Am	M4	6; 10; 15; 18.5	4/0.66					
		2m	M5	10.6; 20; 30	8.2/1.2; 6.6/1; 5.2/0.8					
		2m	M5	8; 15; 22.5	8/1.3; 6.3/1					
		3m	M6	8; 15; 22.5	6.3/1; 5/0.8; 4/0.66					
		3m	M6	8; 15; 22.5	6.3/1; 5/0.8; 4/0.66					
63000	(GM 7630) GM 7630 [GM 7630]	1Am	M4	10.6; 20; 30	6.6/1; 5.2/0.8					
		2m	M5	8; 15; 22.5	6.3/1; 5/0.8; 4/0.66					
		2m	M5	12; 18; 22	6.3/1					
80000	GM 7800 [GM 7800]	1Am	M4	8; 15; 22.5	5/0.8; 4/0.66					
		2m	M5	12; 18; 22	5/0.8; 4/0.66; 3.2/0.5					
100000										

A subject you cannot afford to neglect: drive group (FEM group) selection

Apart from the type of hoist required, the load capacity, the hook path and the lifting speed, the drive or FEM group is one of the main criteria to consider when selecting a hoist. The drive group must be selected to ensure that the hoist is used for its intended purpose. Standard hoists are normally designed for a mean theoretical service life of 10 years, subject to operation in accordance with FEM 9.511. If the drive group selected is not appropriate in view of actual service conditions, the actual service life may be considerably shorter than 10 years. The results are excessive expenditure for maintenance, repairs and overhauls. The crane operator is under an obligation to take appropriate action to ensure that the expended portion of the service life does not exceed the theoretical service life stated in the operating instructions. When the theoretical service life has expired, the hoist must be decommissioned. Continued operation is allowed if it has been determined that there are no objections to continued operation and the conditions for continued operation have been defined. Normally, a full overhaul of the hoist will be required. In general, the inspector requires the hoist to be overhauled. The objective of these requirements is to ensure that each hoist is only operated within its safe working period (S.W.P.).

The following table indicates the theoretical service life D in hours for FEM groups 1Bm, 1Am, 2m, 3m and 4m.

Line	Drive group	1Bm/M3	1Am/M4	2m/M5	3m/M6	4m/M7
1	light	3 200	6 300	12 500	25 000	50 000
2	medium	1 600	3 200	6 300	12 500	25 000
3	heavy duty	800	1 600	3 200	6 300	12 500
4	very heavy duty	400	800	1 600	3 200	6 300

If the mean working time t_m and the load spectrum are known, the correct drive group in accordance with DIN 15020 or FEM 9.755 can be selected using the following table.

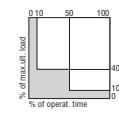
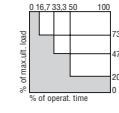
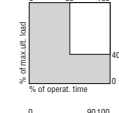
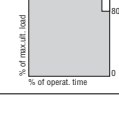
Load spectrum	Definition of load spectrum	Mean working time t_m per working day in h	Drive/FEM group in accordance with DIN 15020 or FEM 9.511				
			1Bm	1Am	2m	3m	4m
1 (light)	($k \leq 0.50$) only operated at maximum load in exceptional cases, mainly operated at very low load, small dead load		≤ 2	2 - 4	4 - 8	8 - 16	> 16
2 (medium)	($0.50 < k \leq 0.63$) operated quite frequently at maximum load, operated continuously at low load, medium dead load		≤ 1	1 - 2	2 - 4	4 - 8	8 - 16
3 (heavy duty)	($0.63 < k \leq 0.80$) operated frequently at maximum load, operated continuously at medium load, heavy dead load		$\leq 0,5$	0,5 - 1	1 - 2	2 - 4	4 - 8
4 (very heavy duty)	($0.80 < k \leq 1$) operated regularly at maximum load, very heavy dead load		$\leq 0,25$	0,25 - 0,5	0,5 - 1	1 - 2	2 - 4

In addition to the mean working time per day, t_m (total hours cumulated of operation of the hoist per day), the correct assessment of the load spectrum is essential for selecting the appropriate drive group. The value t_m is given by the following equation:

$$t_m = \frac{2 \times \text{mean lifting height (m)} \times \text{load cycles (1/h)} \times \text{working time (h/day)}}{60 \text{ (min/h)} \times \text{lifting speed (m/min)}}$$

Mean lifting height:

the average hook travel under actual operating conditions

Load cycles:

the average number of lifting operations per hour. A load cycle consists of one lifting and one lowering operation, i.e. two hook movements (lifting operations with an empty hook as a result of process conditions must also be taken into account in determining load cycles, but also make the load spectrum determined less severe).

Working time:

average working time per day within which the above-mentioned average load cycles per hour are performed.

Lifting speed:

average lifting speed (normally the maximum lifting speed) at which the load cycles are performed.

The selection of the next highest FEM group results in a doubling of the theoretical service life if the operating conditions assumed remain unchanged.

FEM 9.755 gives more detailed information on this complex subject. We would be pleased to send you our ABUS planning service leaflet for determining the correct FEM group on request.

ABUS electric wire rope hoists – the technology

GM electric wire rope hoists demonstrate the high quality level achieved by ABUS:

- developed using advanced calculation and CAD programs
- optimized by continuous incorporation of experience obtained in testing and use
- future-oriented technology: two-speed hoist and cross travel drives, standard motor protection functions
- reliable, durable units for load capacities from 1 t to 100 t with the CE mark for use in the European Economic Area; 7 basic types available in various models with speeds, lifting heights and drive groups for a wide range of applications.
- made and tested at advanced production facilities, with an ISO 9001 quality system ensuring constant high levels of quality

Hoist design

ABUS wire rope hoists are extremely compact units, robust and easy to maintain, which can easily stand up to comparison with the competition. Outstanding design features include the parallel configuration of rope drum and hoist motor, modular design and the functional arrangement of all components. Joints with direct fits between components such as hoist motor, gears, rope drum and limit switches save parts and improve reliability. For the largest model, GM 7000, hoist gear units with two-motor drive systems are used because two smaller motors with half the rating of a larger motor have greater thermal reserves and lower noise emissions than one large hoist motor.

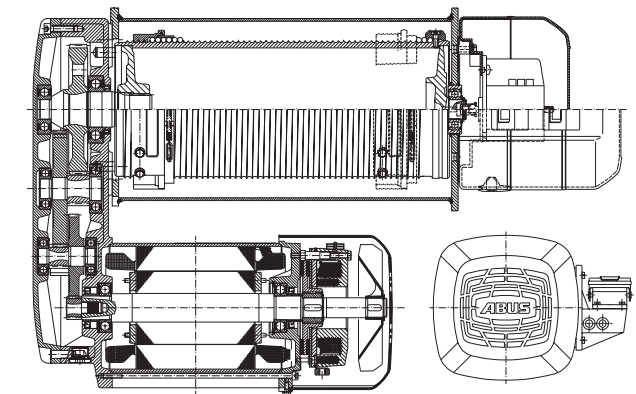

Hoist motors

ABUS uses sturdy cylindrical rotor pole change motors with elegant continuous cast aluminium sections, integrated safety brakes and easy-to-use plug and socket connectors. Hoists are supplied as insulation class F, IP55 protected units.

Stator subdivisions are optimized for higher electrical efficiency, smooth running and improved thermal capacity in service with frequent switching operations, allowing smaller sizes compared with conventional motors. Automated winding production ensures reproducible quality.

ABUS now uses windings designed for use in several voltage ranges for different mains voltages and frequencies. As a result, there has been a significant reduction in the variety of types installed and ABUS has been able to ensure more rapid spare parts service world-wide.



Hoist gears

Precision flat bevelled gear units in light alloy housings with case-hardened gears, high-grade surface treatment and permanent oil lubrication ensure high reliability and smooth running with a minimum of maintenance.

Hoist brakes

Dual-disk electromagnetic brakes ensure automatic braking on power failure. Environmentally sound brake linings designed for approx. 1 million braking operations allow long maintenance intervals.

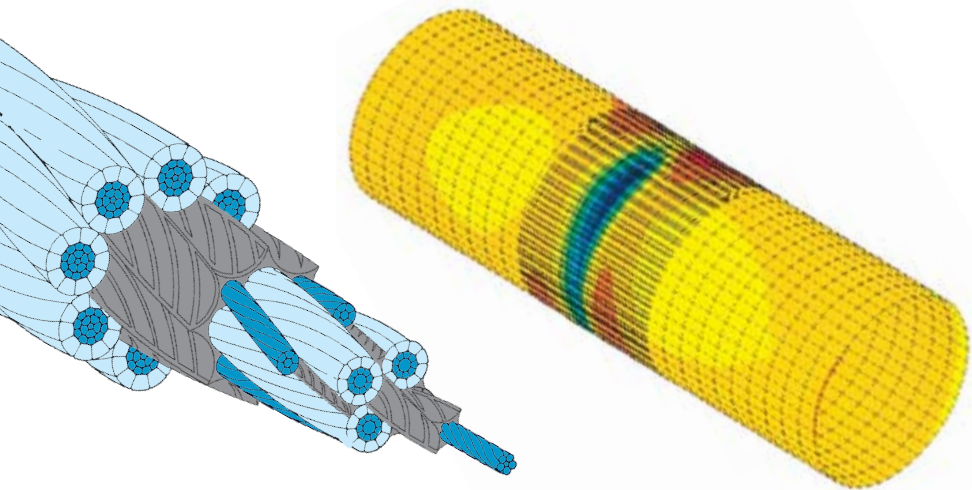

ABUS wire ropes

- improved tensile strength
- enhanced fatigue strength under cyclic bending stresses
- high structural coherence
- improved abrasion resistance
- enhanced corrosion protection

Rope drums

Developed and optimized with the aid of finite element simulation programs

Rope drive

Low weight and compact dimensions are top priorities in the ABUS design brief, which is why ABUS development engineers have selected high-strength galvanized wire ropes with compacted strands and a special structure for use on ABUS wire rope hoists.

Combined with wear-resistant rope drums and rollers, these ropes make it possible to produce an extremely compact rope drive without making any sacrifices in terms of reliability and durability.

Electrics

The control systems used for ABUS wire rope hoists feature proven technology and are of modular design, covering a very wide operating range. All motion functions are designed for two-stage pole change operation. The systems are designed for ease of installation and maintenance and reliable operation, with fuseless circuitry, ducted wiring and non-screwed terminals.

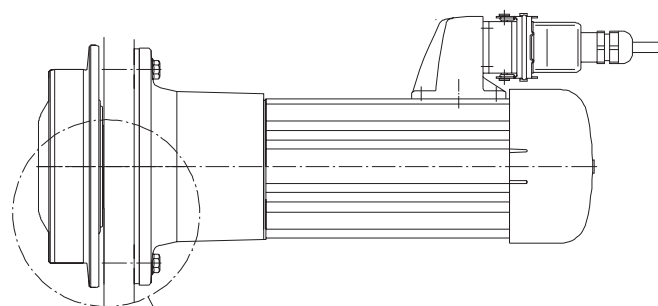

Supporting structure, trolleys and drive systems

The hoist types described on pages 6 to 9 are the result of integrating standard hoists in chassis designed for different applications and combining them with various types of travelling gear. Compact dimensions, low headroom dimensions, favourable end approach dimensions, practicality and quality are outstanding features of all these hoists. In the case of crab units, the supporting structure is connected to the end carriages by machined joints and bolts, allowing accurate wheel positioning to precision engineering standards. In addition, articulated end carriage joints ensure that all four wheels are always firmly positioned on the tracks and that the wheel loads on the crane bridge

are properly distributed in accordance with the structural design of the system.

The travelling gear includes flanged wheels with roller bearings. In combination with individual drive systems, they form compact direct drive units requiring almost no maintenance. As regards mains operation, pole change cylindrical-rotor motors with smooth start-up characteristics, additional balance weights on the motor shaft and integrated disk brakes make for smooth acceleration and braking almost unaffected by the load on the system. Other optional features available for even smoother running include smooth starting units and smooth switching relays.

ABUS quality standards: Precise, modern production processes



Steel trolley frames are manufactured using a 10-axis welding robot, ensuring short processing times and constantly high welding quality.



Advanced CNC lathes are used to turn the rope drums in one operation, an approach that ensures perfectly smooth running of the rope drums during operation.



Assembly of monorail hoists

The first step towards your ABUS wire rope hoist

Fax Number
08 9378 3689

Just copy this fax form, complete it and return it to us. We will send you a competitive quotation by return.

Company: _____	Post code: _____
Address: _____	Contact name: _____
Town/City: _____	Phone/Fax: _____

Information on the type of wire rope hoist required

Type/load capacity

Monorail hoist Type E <input type="checkbox"/> U <input type="checkbox"/> Model in acc. with selection table ¹⁾ _____ Load capacity (SWL) _____ kg Lifting speed _____ m/min FEM group _____ Hook path _____ m	Crab unit Type D <input type="checkbox"/> __ <input type="checkbox"/> Z <input type="checkbox"/> __ <input type="checkbox"/> Model in acc. with selection table ¹⁾ _____ Reeving _____ Cross travel speed _____ m/min Operating voltage _____ V _____ Hz Control voltage _____ V
--	---

For use as

- | | |
|---|---|
| <input type="checkbox"/> stand-alone hoist complete with hoist and travel contactors, main contactor, control transformer and push button pendant | Special accessories (see pages 11 to 13)
Please enter the key dimensions of your crane track/girder in the sketches below. |
| <input type="checkbox"/> hoist on existing crane (main contactor, control transformer and push button pendant already available ²⁾) | |

Key dimensions

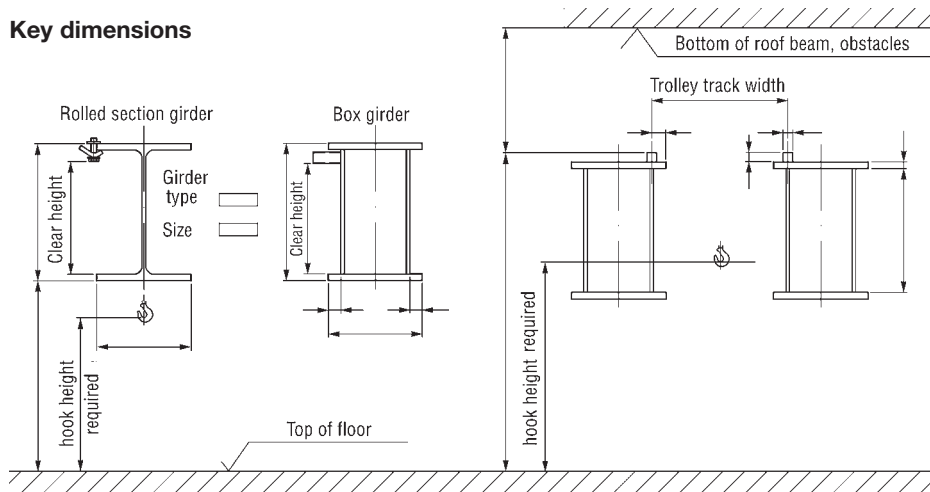

- 1) For selection tables and explanatory notes, see pages 14 to 17.
- 2) The existing crane control system must be compatible with the control system of the ABUS wire rope hoist. If your control system was not supplied by ABUS, please attach a circuit diagram.

Australia – Eilbeck Cranes
 6 Moorlands Road · Ingleburn NSW 2565 · Ph. 61 (0)2 9829 3700 · fax 61 (0)2 9829 3500 · e-mail: t.eilbeck@eilbeckcranes.com.au
 23 Jackson Street · Bassendean WA 6054 · Ph. 61 (0)8 9279 4800 · fax 61 (0)8 9378 3689 · e-mail: j.hodges@eilbeckcranes.com.au
 12 Sudbury Street · Darra QLD 4076 · Ph. 61 (0)7 3271 3790 · fax 61 (0)7 3271 3791 · e-mail: p.durrington@eilbeckcranes.com.au

Australia – Modular Cranes
 33 Colbert Road · Cambellfield VIC 3061 · Ph. 61 (0)3 9357 9877 · fax 61 (0)3 9357 9822 · e-mail: tony@modularcranes.com.au

New Zealand – Baker Cranes
 10 Aerovista Place · Wiri, Auckland · Ph. 64 (0)9 277 0736 · fax 64 (0)9 277 0736 · e-mail: baker.c@xtra.co.nz

Vietnam – AVC
 206 Road · Lac Hong Commune · Van Lam District · Hung Yen Province · Vietnam
 Ph. 84 321 980 410 · fax 84 321 980 411 · e-mail: avc-abus@hn.vnn.vn